

21-ე საუკუნის რევოლუციების მეორე ტალღა - არაბული გაზაფხული

ბარბაქაძე სოფიო
საქართველოს უნივერსიტეტი

21-ე საუკუნის დასაწყისმა მსოფლიოს თავი რამდენიმე მნიშვნელოვანი მოვლენით დაამახსოვრა, რომელთა შორის ერთ-ერთი უმთავრესი რევოლუციების სრულიად ახალი ფორმის-ხვერდოვანი რევოლუციების გამოჩენა იყო. ხვერდოვანი რევოლუციის ცნების, მისი ხასიათის, წარმოშობის მიზეზებისა და სამომავლო განვითარების ირგვლივ აზრთა სხვადასხვაობა წარმოიშვა. ამასთანავე, 21-ე საუკუნის მეორე ათწლეულმა თან მოიტანა ხვერდოვანი რევოლუციის ახალი ფორმა, რომელიც „არაბული გაზაფხულის“, „არაბული გამოღვიძებისა“ და „უკრაინის რევოლუციის“ სახელითაა ცნობილი. სტატის მიზანს წარმოადგენს სწორედ ამ ახალი ფორმის რევოლუციის სიღრმისეული ანალიზი, მისი რევოლუციური პროცესის შესწავლა, არაბული რევოლუციის შედარება ტრადიციულ და ხვერდოვან რევოლუციებთან და მისი მნიშვნელობის დადგენა როგორც უშუალოდ ახლო აღმოსავლეთისთვის, ისე ხვერდოვანი რევოლუციების „პირველი ტალღის“ ქვეყნებისთვის უპირველეს ყოვლისა-საქართველოსთვის.

The Second Wave of Revolutions in the 21st Century - the Arab Spring

Barbakadze Sophio
The University of Georgia

The 21st century has been marked by several notable events, among them the emergence of a new form of revolution - a so-called "color revolution." There is a controversy over the definition, the character, the causes and the future of this phenomenon. While these questions still remain unanswered, yet another form of revolution has emerged known as an "Arab Spring", "Arab Awakening", and a "Jasmine Revolution." This article will provide an in-depth analysis of this new form of revolution. This will include studying the process of Arab revolutions, comparing the process with those of the traditional and of the Color Revolutions, defining its importance for the Middle East as well as for countries which have recently undergone color revolutions, first of all, for Georgia.

"The Arab revolt that started in Tunisia has opened a Pandora's Box that cannot be closed by brutally forcing opposition forces into submission" (Dorsey, 2011).

The spring of 2011 saw a rising wave of demonstrations in the countries of the Arab world. "In what became known as the Jasmine Revolution, a sudden and explosive wave of street protests ousted the authoritarian president, Zine el-Abidine Ben Ali, who had ruled with an iron hand for 23 years. On January 14, Mr. Ben Ali left the country, after trying unsuccessfully to placate the demonstrators with promises of elections" (The New York Times, 2011) this was the way the news about Tunisia (formerly a relatively peaceful "European country in Africa," afterwards known as the "cradle of Jasmine Revolution") were reported by all media sources throughout the world. After the successful revolution in Tunisia, the wave of demonstrations spread to Algeria, Morocco, Egypt, Jordan, Libya, Yemen, Bahrain, Oman and Syria (Fig. 1).

Signs of instability were observed in Kuwait, Lebanon, Djibouti, Saudi Arabia and Sudan. However the wave of unrest has passed the regional boundaries and has been echoed in the recent demonstrations in Sub-Saharan Africa, Europe, Caucasus, Asia and the Americas. Due to the limited size of this article, I will concentrate just on the events in Georgia later on.

Why the Arab Spring is not a true "Colour Revolution"?

From the very first days of the Arab Spring, parallels were drawn with the color revolutions of the first decade of the 21st century (which swept the post-Soviet regimes in a number of former-Soviet states including Georgia and Ukraine). The article will try to examine the revolutionary processes of the Arab Spring to find out whether "color revolution" is an appropriate term for this new phenomenon. We will analyse the recent processes in the Arab world to determine their general characteris-

tics and finally, to categorise the Arab Spring either as a “traditional” or a truly “colour” revolution. The best way to analyse any revolution is to go

Figure 1
Map of Arab Spring

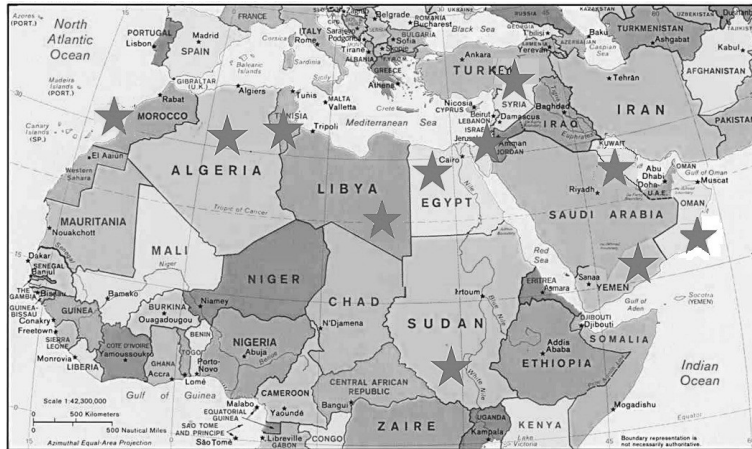

Retrieved from:
Google.com

step by step through seven phases of the revolutionary process (Fig No.2) before making any conclusions regarding its nature. However, as long as the Arab Spring has occurred rather recently, we can only put the first three phases (“Crisis”, “Fall of old regime” and “Honeymoon”) under discussion. Therefore, whatever the conclusions will be at the end of this article, they will definitely leave a space for contemplation.

Crisis and fall of the old regime are the first two phases of the revolutionary process. “As new desires arise, or as old desires grow stronger in various groups, or as environmental conditions change, and as institutions fail to change, a relative disequilibrium may arise and what we call a revolution break out” (Brinton, 1938). Usually, the financial, economic and social crises of the pre-revolutionary regimes are the roots of all revolutions- both traditional (France- 1789-1799, England- 1640-1660, America- 1775-1783, Russia- 1917) and color revolutions (Serbia’s 2000 Bulldozer Revolution, Georgia’s 2003 Rose Revolution, Ukraine’s 2005 Orange Revolution, Kyrgyzstan’s 2005 Tulip Revolution). However similarities between traditional and color revolutions end there. In the traditional revolutions fall of the old regime is preceded by the government’s *violence* against its people in an attempt to curb the riots and its failure to do so. In the color revolutions the government *doesn’t engage in violence* against the demonstrators - the only exception being Kyrgyzstan - with some violence occurring between demonstrators and government supporters (which seemed more like spontaneous clashes than a government-initiated violence).

Figure No. 2
Phases of the Revolutionary Process

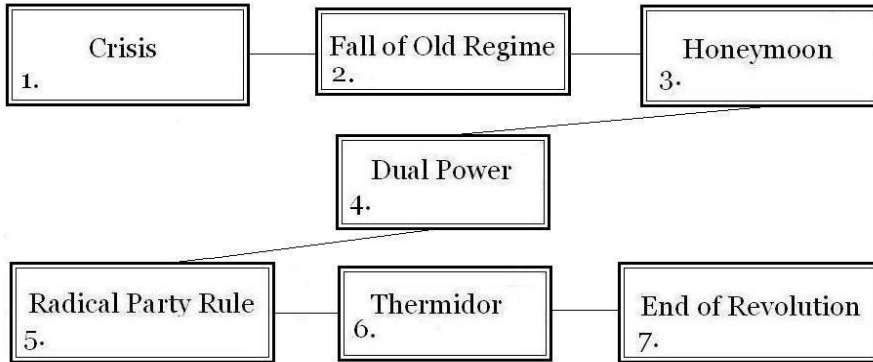

Roots of Arab Revolutions are no different: deep social, ethnic and religious problems of the Arab societies, most prominent of these being years of stagnation under one ruler and lack of a political representation of ethnic or religious minorities (for example, the Shiites in case of Bahrain) or both.

The author of the book “Anatomy of Revolution” Crane Brinton began his discussion of the phases of a revolutionary process by comparing a revolution to a disease, symptoms of which may be present for decades, far before the disease takes a severe form.

First symptom of a coming revolution is a growing *discontent over financial problems* in all social classes: For a number of reasons the wealth is not evenly distributed in a society, and even those who are relatively well-off, find the government hindering their economic activities. In the case of the American Revolution, the British policy had led to the accumulation of discontent among the American merchants while in the case of the French Revolution on-going tax reforms threatened the well-being of the higher classes. Same was true for the Color Revolutions: economic stagnation, overwhelming corruption and lack of prospects for doing business accumulated aggression inside all social classes of the post-soviet states. Same is partially true about the Arab Revolutions: Tunisia has seen a number of protests of the unemployed for years, public anger was fuelled after the Wikileaks published a report of a diplomat who attended a dinner with the family of the president Ben Ali: “A beachfront compound decorated with Roman artifacts; ice cream and frozen yogurt flown from St. Tropez, France; a Bangladeshi butler and South African nanny; and a pet tiger in a cage” (NY Times, 2011). Egyptian demonstrators have protested against high unemployment and rising prices of food (among other issues). Although

corruption index was higher in Libya than in both Tunisia and Egypt, the Libyan population enjoyed higher living standards, therefore demands for economic reforms were less frequently heard there (Howard, 2011).

Second symptom of a revolution: Unequal opportunities of people belonging to different classes were seen as a violation of *natural order* during traditional revolutions. The same problems were encountered by pre-color revolution societies and the societies of the Arab countries - this time the problems were named *violation of universal human rights*. Globalization and global exchange of information has increased the gap between what the governments should be and what they really are. Even the Syrian president Bashar Al-Assad (who rules a country by means of an almost 50-yr-long state of emergency) has admitted recently in a televised speech that a "government has to keep up with the aspirations of the people" (MWC News, 2011). Lack of democratic reforms has been perceived as a violation of natural order of things. We might say that this factor - and not economic problems - is the primary driving force of the Arab Revolutions. This assumption leads us directly to the revolutionary symptom No. 6: the intellectuals and ideas in the opposition (Table No.1).

"No ideas, no revolution," stated Brinton (Brinton 1938). Any revolution needs an idea to unite people, a "just cause" for what one should sacrifice one's life. Ideas may vary from "Liberty, Equality, Fraternity" of the 18th century France to "God, Syria, Freedom" in Syria to "people want to bring down the regime" elsewhere in the Arab world in the 21st century; however they still have a lot in common including, first of all, the force of uniting large numbers of individuals behind one cause. "We find that ideas are always a part of the prerevolutionary situation This does not mean that ideas cause revolutions, or that the best way to prevent revolutions is to censor ideas. It merely means that ideas form part of the mutually dependent variables we are studying" (Brinton, 1938).

Ideas are generated by a definite group of people - intellectuals, people with high education, usually coming from middle or upper classes, people who deny the ruling class their allegiance to begin anti-government activities. These are the people who begin to doubt the way their societies operate. i.e. *societies de pensee* in France, *the merchants' committees* in America, groups of *anarchists, westernizers, socialists, liberals, nihilists* and others in Russia.

In the Color Revolutions, individual intellectuals had also played their part, however the main driving force of the revolution were *opposition parties, youth organizations and NGOs*. During the Arab revolutions the educated *intellectuals (teachers, students, lawyers, etc.) and the*

public figures took the side of the demonstrators. However they failed to consolidate into an organization to further coordinate their activities and to drive the opposition forces forward. Up to now, there is almost no organization among protesters in Syria. The National Transitional Council is the only organizational unit in the Libyan opposition - however its objective is limited to coordinating resistance of the towns controlled by rebel forces. Situation was quite different in Egypt, where a number of organizations, including youth organizations (Youth for Justice and Freedom, Coalition of the Youth of the Revolution, Popular Democratic Movement for Change, National Association for Change and others) took an active part from the beginning of the street demonstrations. These are the organizations which also organized a "second day of rage" on the 28th of May with the demands to end the post-revolutionary military rule conducting mass violations of human rights from the very first days of coming to power (Martin, 2011).

Another important difference: the Color Revolutions would typically start *after a fraudulent election*, while the Arab revolutions began against an authoritarian ruler *without an election stolen*. (In this aspect, the Arab Revolutions resemble traditional revolutions.) At this point, we come upon *symptom No.3*: optimistic expectations of the society which are downplayed because the government is unwilling or unable to change.

The fact that the Color Revolutions were preceded by elections is much more important than it may seem. Actually it is the detail that contributed to a non-violent transition of power for several reasons. First, the pre-revolutionary governments had taken international commitments to guarantee free and fair elections. Therefore the opposition parties were permitted to conduct active election campaigns which informed and mobilized the society already in the pre-revolutionary period. For example, in Georgia all parties began election campaigns months before the Rose Revolution actually began. Political parties were granted free television time to articulate their agendas, political leaders took part in talk-shows and television debates. Due to mass flow of information, the society was highly politicized, politics being most popular topic of discussion everywhere - in families, in transport, in schools and universities throughout the country. Things were different in the Middle East: The opposition didn't have a chance to either organize itself, or to formulate its agenda and to inform the society about its aspirations. This is why the Arab Revolutions are called the "Facebook and Twitter Revolutions"- the social media being the only means of communication. According to one activist's post on twitter: "We use Facebook to schedule the protests, Twitter to coordinate, and YouTube to tell the world" (Howard, 2011). Let's take into account two

things: 1) the aggressive internet-censorship in all Arab countries most prominently in Syria, Egypt, Bahrain and Libya; 2) far less people (mostly youth) has access to the internet than to television. Due to these, the revolutions were spontaneous and fully depended on the aggression and dissatisfaction accumulated in the society for decades. These are the reasons why the Arab revolutions are much more difficult to organize, much more prolonged and violent than the color revolutions were. The Arab revolutions are also more difficult to predict. To measure vulnerability of any Arab country to the revolution The Economist has introduced its "*Shoe throwers index*" which has been quite helpful in making predictions and which represents a combination of various data: "35% of the index value is accounted for by the share of the population that is under 25; 15% is accounted for by the number of years the government has been in power; 15% by both corruption and lack of democracy indices; 10% by GDP per person; 5% by an index of censorship and 5% by the absolute number of people younger than 25" (The Economist, 2011).

The elections in Georgia in November 2003 made a great contribution to the *internationalization* of the Rose Revolution: great numbers of international organizations and foreign reporters arrived to observe the election: International Election Observation Mission (composed of the Parliamentary Assemblies of the OSCE), the Office for Democratic Institutions and Human Rights (ODIHR), International Society for Fair Elections and Democracy (ISFED) were some among many organizations which observed the elections to report the election fraud. It was these international organizations which provided the Georgian opposition with a "just cause" to fight for and ultimately led the country to the change of power, while the international media sources provided a 24-hour coverage of the events. Actually, the organizations and reporters who came to Georgia to monitor elections became witnesses of the revolution. International presence was one of the reasons why the Shevardnadze's government did not use force to suppress the demonstrations. On the other hand, the international presence was minimal in the countries of the Arab Spring, the only media source which reported the on-going events being Al-Jazeera, the international organizations present being the African Union, the Arab League, the Amnesty International and the International Human Rights Watch (in the context of years of repression these organizations would be much surprised to see a peaceful transition of power than the violence that occurred, therefore they didn't do anything what they were not doing through years, namely, calling for reforms which, traditionally, went unheeded.) This was why the governments did not feel particularly uncomfortable while conducting bloody attacks against their populations.

Here we should give a separate space to the *international intervention* on the side of the opposition in Libya. The event itself is of an utmost importance for regional as well as for global politics and requires far more space for analysis than this article can provide. Therefore here we can only point out the following: This is the only case in history of revolutions when a foreign force intervened on the side of the revolutionaries and took on itself almost the whole burden of military operations. If this trend will be repeated in other Arab countries (Syria being a most prominent candidate), we can speak of a totally new form of revolution which can be not only incited, planned, financed or directed from outside, but also actually accomplished by foreign forces. (In this case we could question ourselves whether the action of fighting for a foreign revolution is actually a revolution, also where does the line separating such revolution from an intervention like that of the 2008 Russo-Georgian war go and finally, what can we do to such universal principles as sovereignty and territorial integrity which directly forbid intervention in domestic affairs of states and which has been the bedrock of the international system for centuries.)

The expectations about what the regime change would be like was also important: In Georgia, the change of government was expected to take place by elections and later by peaceful resignation of the old regime. Expectations for escalation of the demonstrations to civil war were low most of the time (not to take into consideration several incidents including mobilization of the security forces and pro-government demonstrations). A common demonstrator which made a decision to join the manifestations did not have to fear for his life. In case of Arab revolutions expectancy for violence was very high. "Martyr" became a synonym for a "demonstrator" during Jasmine Revolutions, as each person going out to demonstrate had no guarantee of returning home alive. All of this information being summarized in the table 1. See on the next page:

So far, Jasmine Revolutions have succeeded in two Arab countries - Tunisia and Egypt (second phase of the revolutionary process, namely, the fall of the Old Regime). Power has been transferred to the former opposition (third phase, namely, the Honeymoon). The 4th and 5th phases of the revolutionary process (the Dual Power and the Radical Party Rule) in Tunisia and Egypt are especially interesting to observe, as long as here is where the differences begin. At this point situation in Tunisia can be generally assigned to the category of "dual power:" the interim government consists of 60 opposition parties, oldest and most popular of them being Ennahda ("renaissance" in Arabic). While elections have been postponed (allegedly because big numbers of Tunisians are not officially registered yet), fears arise regarding the tolerance and moderation of the party: "Rumors of attacks on unveiled women and artists, of bars and brothels sacked by party goons, of plots to turn the country into a caliphate [circulate among the coastal elite]. Ennahda's popularity and organizational strength are of growing concern to many activists and politicians, who worry that the secular revolution of January might see the birth of a conservative Islamic government in July" (NY Times, 2011).

Table №1

Symptoms of Revolution

Symptoms of a revolution	Traditional	Color	Arab
1. All social classes are discontent	√	√	√
2. People feel restless and held down by unacceptable restrictions on society, religion, economic activities or government.	√	√	√
3. People are hopeful about the future, but they are being forced to accept less than they had hoped for.	√	√	√
4. People are beginning to think of themselves as belonging to a social class, and there is a growing bitterness between social classes.	√	-	-
5. The social classes closest to one another are the most hostile.	√	-	-
6. The scholars and thinkers give up on the way their society operates.	√	√	-
7. The government does not respond to the needs of its society.	√	√	√
8. The leaders of the government and the ruling class begin to doubt themselves. Some join with opposition groups.	√	√	√
9. The government is unable to get enough support from any group to save itself.	√	√	√
10. The government cannot organize its finances correctly and is either going bankrupt or trying to tax heavily and unjustly	√	√	-
11. Impossible demands made of government which, if granted, would mean its end.	√	-	-
12. Unsuccessful government attempts to suppress revolutionaries.	√	-	√
13. Revolutionaries gain power and seem united.	√	√	-

In G. Anchabadze's opinion "For knowing the precise number of military force they periodically held a census. By the evidence of David's chronicle, the census of 1123 showed that the number of Kipchaks who carried arms reached 50,000. Since the natural growth of population couldn't be 20 %, it is suggested that in 1119-23 new groups of nomads from the North were resettled" (Anchabadze, 1990, p. 111).

P. Golden refers to I. Javakhishvili and shares his suggestion that the number of the settled foreigners was – 225.000 (Margishvili, 2006, p. 62).

By F. Kirzi-oghlu, the number 225.000 introduced by I. Javakhishvili was diminished and considering 6 people in one family, he determined the total number as 300.000, since the scholar multiplied 50.000 by 6 (Kirzioglu, 2002, p. 125). A. Yunusov shares the opinion (Unusov, 2000, p. 32).

N. Murghulia and V. Shusharin concluded that for determining the total number of the troopers that came to Georgia, one has to rely on the data of a census by David's chronicler (50.000) (Murghulia, Shusharin, 1998, p. 96). Such an interpretation of the text is reflected in the Russian translation of the Georgian chronicle: "He instantly summoned all his troops. By his order all came from his kingdom. He rose against Sultan; and Kipchaks, who were counted over again that time, were 50000" (Murghulia, Shusharin, 1998, p.215). The translation is not adequate to the Georgian text. Before launching a campaign to Shirvan the Georgian king gathered the army and as David's chronicler notes, "He quickly summoned all his army and by his order an army from all his kingdom gathered before him and came forward against Sultan; Kipchaks were counted over again; the fighters that he found, were 50000. As soon as Sultan was informed about their arrival, power and number of his army, he was scared, left the place where was camped and was sheltered in the city" (Life of King of Kings David, 1992, p. 194). In the considered context, the number 50000 implies the army as a whole and not only Kipchaks. It also seems to be confirmed in the following excerpt of the same chronicle. Before taking Anisi, David once again called his army: "He quickly sent written invitations and on the third day 60000 warriors were before him. He moved and on the third day took the city" (Life of King of Kings David, 1992, p. 197). As one can see, there is no big difference between those two numbers – 50.000-60.000. The indication of the 60.000 (in Georgian - "samotsi" – means "three twenties") in the latter context can probably be explained by the desire to repeat number "three", which is preferable in "Kartlis Tskhovreba" because of its sacral meaning: "On the third day "samotsi" (three twenties) thousand warriors stood before him. He raised and on the third day easily took the town Anisi and its fortresses and villages and the lands around Anisi" (Life of King of Kings David, 1992, p. 197).

The evidence of Matheos Urkhaetsi, in which the participants of the Battle of Didgory are named one by one, seems to be more correct: "...With 40.000 strong and courageous men and warriors, experienced in warlike activities; He also had other troop from the Khapchakh (Kipchak) king – 15000; bold and selected men from Ossetian tribe – 500, Franks – 100" (Murghulia, Shusharin, 1998, p. 134). The evidence of the Armenian chronicler of the 13th c. Smbat Sparapet, according to which the king "gathered all his army, invited for help 40.000 Kipchaks, 18000 Alans, 10000 Armenians, 500 Franks" (Murghulia, Shusharin, 1998, p. 83-84) - seems less reliable.

According to the Georgian chronicler, settling the Kipchaks helped David to be successful. Just after that, the Georgian king "began to raid Persia, Sharvan and Great Armenia" (Life of King of Kings David, 1992, p. 185). After the settling of Kipchaks, they are supposed to have participated in all campaigns, no matter the Georgian chronicler mentions them in all cases or not.

The Arab chronicler Ibn al-Athir (13th c.) indicates that in the Battle of Didgori in 1121, which was followed by joining Tbilisi in 1122, Kurjs (Gurjs) came out jointly with Kipchaks. This record alone is sufficient to make it obvious that Kipchaks were the advanced guard of the Georgian army. That is why before the battle "200 men from Kipchaks came forward- entered the midst (of Moslems) and shot arrows" (Ibn al-Athir, 1966, p.567).

An issue which draws our attention is the process of assimilation of Kipchaks who were settled in Georgia and their relationship with the local population. According to P. Golden, "The use of a large foreign army (the Kipchaks) to be settled in the country was a daring move which, had the arrangements soured, could have had disastrous, perhaps fatal, effects on Georgia" (Margishvili, 2006, p. 61).

The evidence of David's chronicler that "Bulk of Kipchaks day by day became Christians and their big number was added to Christianity" (Life of King of Kings David, 1992, p. 185) in the Georgian scholarly literature is interpreted with some exaggerations. According to I. Javachishvili, Kipchaks who were resettled in Georgia, "learned Georgian and became Georgians and no one from their descendants was left as Kipchak, but everybody without any compulsion became Georgian voluntarily" (Javakhishvili, 1983, p. 216).

The opinion above was shared by other scholars. However, related records fail to confirm this suggestion and present a different picture.

David's chronicler emphasized that from the very beginning - after settling Kipchaks in Georgia to the king tried assimilate them; he started the process by their conversion to Christianity. However, the process of Christianizing as well as the Georgianizing of the foreigners was not so successful and their relationship with the local population as well as with

the king himself was rather complicated. The chronicler does not hide the fact that Kipchaks frequently took prisoners from among the population, and the king was forced to ransom them: "Who can count the prisoners who were liberated by Him and were ransomed from Kipchak relatives by fee" (Life of King of Kings David, 1992, p. 210). P. Golden suggests that problems came from other Kipchaks who were not in Georgian service and were not allies of Georgians (Margishvili, 2006, p. 74-75). Indeed, "Kipchaks of Daruband" are also mentioned in the source. However this suggestion is not easy to share fully, since one can see that Kipchaks, who were settled in Georgia, did not spare the Georgian king him, frequently betrayed him and organized plots against him. "How many times Kipchaks planned treason: established leaders, bold, some of them with sword, some with spear, some with In Egypt hundreds of thousands of people returned to the Tahrir square in Cairo to demand an immediate end of the military rule, which came to power after the Jasmine Revolution. "Demonstrators voiced calls for a "second revolution," expressing widespread sentiment that the revolution that brought down Mubarak has not resulted in any fundamental improvement in the conditions of life for the masses of working people, small farmers and agricultural laborers" (Martin, 2011). Various sources report numerous violations of human rights and violations of fair trial rights in Egypt: Thousands of civilians have been tried before the military courts for "crimes" like "protesting peacefully, breaking curfews, and various bogus charges, including possessing illegal weapons, destroying public property, theft, assault, or threatening violence. Those charged were judged guilty by accusation and denied lawyers of their choice to represent them" (Lendman, 2011). Let us bear in mind that such crimes are the subject of a civil, not a military court. Current unrest in Egypt makes it clear: The Egyptian revolution has missed the phase of "dual power" and has directly succumbed to the phase of the "radical party rule," also called "the reign of Terror and Virtue." According to the author of "Anatomy of Revolution," this phase is characterized "on the one hand with ... abundance of executions and repression; and on the other hand with "organized asceticism" ruling out such "social vices" as gambling, alcoholic drinks, and prostitution" (Brinton, 1938). Current "virginity tests" reportedly conducted against young women demonstrators speak for themselves. "One detainee, Salwa Hosseini, says she and the other 16 women were tied up, slapped, shocked with a stun gun, and called prostitutes, then strip-searched and forced to undergo the virginity

exam by a man in a white coat — while soldiers watched” (The Week, 2011).

From the very first phase of analysis, it is evident that the Arab Revolutions have lost the main attribute of the Color Revolutions - non-violent character of the revolutionary process. The security forces have attacked demonstrators in Syria, Libya and Bahrain, leaving hundreds dead and injured (thousands, reportedly, have been arrested). This is how a reporter from Al-Jazeera describes situation in Syria: “Syrian regime is likely to follow in the footsteps of Bahrain and beyond. In other words, it's pre-empting further escalation of popular upheaval through a campaign of nation-wide arrests and military deployment to the country's civilian hotspotsSo far, hundreds have been killed in only a few days” (Bishara, 2011). Frequent clashes between the demonstrators and the pro-government activists or the riot police took lives of many in Yemen, Algeria and Oman. (The only exception is Morocco where no violent acts were reported.)

One should not fail to notice that the Jasmine revolutions are in many ways different from the Color Revolutions. In fact, they stand somewhere in-between the traditional and the Color Revolutions, bearing resemblance to both. While the Color Revolutions are “true children” of the 21st century (with the globalization, internationalization of domestic issues, politicization of formerly-not political issues, etc.), the Jasmine Revolutions seem more like the vestiges of the 20th century (mostly because nothing much had changed in the Arab world for the past five decades either in terms of human rights, the freedom of speech or political representation). To be realistic, it was quite impossible to conduct peaceful color revolutions in the Middle East, where the existing regimes, the political traditions, the human rights index, the political, social, economic, ethnic and religious environment, all predicted that revolution - whatever form its process takes - would definitely be accompanied by violence.

Impact of Jasmine Revolutions on Georgia

Wave of Jasmine Revolutions swept the Arab World with violent demonstrations; however it didn't leave the rest of the world untouched. Discussions whether the revolutionary wave would reach Georgia and what its impact on our domestic processes would be like began already in the beginning of the year. Numbers of probable scenarios were written

and discussed in the Georgian media; meanwhile the anti-government protests in fact began in Tbilisi on May 21, 2011. Demonstrations were headed by the ex-parliamentary speaker and leader of the Democratic Movement-United Georgia party Nino Burjanadze. After five days of protests, the demonstrations were suppressed by police forces. No further protests been planned so far.

One of the purposes of this article is to reveal why the second revolutionary wave has passed Georgia by. Let us examine the events of May 2011 through the prism of the revolutionary process. According to the author of "Anatomy of Revolution," a revolution is like a virus, a disease accompanied by high "fever" (domestic disorder, civil disobedience, and, in extreme cases, violence). When the "fever" is over and the patient recovers, he may be "immunized at least for a while from a similar attack, ... [t]he parallel goes through to the end, for societies which undergo . . . revolution are perhaps in some respect stronger for it (Brinton, 1938). This is definitely true for Georgia, the country which has undergone the last revolution some only seven years ago. According to one Georgian author: "Georgia has undergone two coups in the last 20 years and the Georgian people know very well what it means to have armed men in the streets. People remember that bitter experience and they will not risk the current social security for indefinite future (Rezonansi, 2011).

The case of Georgia is the best example of the "revolutional immunity." The idea is the following: Revolutions begin with ambitious aims to change everything including the way of life, the way of thinking, the way of how-the-order-of-things-should-be, ultimately, changing the society itself. However, as a patient does not turn into a new man after recovery, so do societies remain mostly the same after revolutions: "Societies which undergo . . . revolution are perhaps in some respect stronger for it; but they by no means emerge entirely remade" (Brinton, 1938). The "revolutional immunity" is the intuitive knowledge that *substantial changes need stability more than revolutions* generated inside the society after results of the first revolution are clear.

The "revolutional immunity" can also be acquired through the theoretical knowledge and the centuries of historic experience: each revolution has a fairly good chance of ending up with a radical government. Probably one example from history would make it clear: Zbigniew Brzezinski (National Security Advisor during presidency of Jimmy Carter) insisted to maintain support of Iran's Shah during the Iranian Revolution. Knowing principles of a revolutionary process Brzezinski foresaw that the moderate Iranian government would not be able to stay in power for long. The only way of keeping radicals away from power in Iran was preventing a revolution. However Brzezinski's recommendations were left unheeded; as a result, a radical Iranian government under Ayatollah Khomeini soon overthrew the moderates and the USA finally lost its strategic partner in the region.

“When President Obama stepped into the State Department on May 19 to deliver his long-awaited speech on the Middle East, he did so amid fears that the Arab Spring was devolving into a Summer of Discontent. Egypt was sagging under a weakening economy and escalating crime; NATO's efforts in Libya were stuck in neutral; the Syrian government was boasting that its rebellion was over. Sectarian tensions were roiling Bahrain and Syria, and a wave of church burnings in Cairo had spawned a week of deadly violence between Muslims and Christians” (Feiler, 2011). This small extract from the Times publication (June 6) very well describes the first results of the Arab revolutions; it can also well serve as a conclusion to this article.

References

- Atlantic Times, 2011, The Arab Revolution is not Over Yet .
- Bishara, M. (2011, April 25), Patterns in the Arab Revolution, *Al-Jazeera*, retrieved on May, 1, 2011 from <http://english.aljazeera.net/indepth/opinion/2011/04/201142519220232412.html>
- Dorsey, J.M. (2011, June 2), Yemen revolt becomes naked struggle for power, *Alarabia*, retrieved on June, 7, 2011 from <http://english.alarabiya.net/articles/2011/06/02/151568.html>
- Feiler, B. (2011, June 6) Faith in the Arab Spring, *Time*, retrieved on June, 7, 2011 from <http://www.time.com/time/magazine/article/0,9171,2074093,00.html#ixzz1NkV9XU9h>
- Howard, P. N., (2011, February 23) The Arab Spring's Cascading Effects, *MillerMcCune*, retrieved on May, 10, 2011 from <http://www.miller-mccune.com/politics/the-cascading-effects-of-the-arab-spring-28575/>
- Huffpost, (2011, March 4), Arab Revolutions: From Tunisia To Egypt, Is This The Beginning Of A Trend? retrieved on May, 10, 2011 from http://www.huffingtonpost.com/2011/02/01/egypt-tunisia-arab-revolution_n_816695.html
- Lendman, S. (2011, May 22), Killings, Detentions and Torture in Egypt, *Inteldaily*, retrieved on May, 30, 2011 from <http://inteldaily.com/2011/05/killings-detentions-and-torture-in-egypt/>
- Martin, P. (2011, May 30), Mass protests demand “second revolution” in Egypt, *The Global Realm*, retrieved on May, 30, 2011 from <http://theglobalrealm.com/2011/05/30/mass-protests-demand-%E2%80%9Csecond-revolution%E2%80%9D-in-egypt/>

- Howard, P. N., (2011, February 23) The Arab Spring's Cascading Effects, *MillerMcCune*, retrieved on May, 10, 2011 from <http://www.miller-mccune.com/politics/the-cascading-effects-of-the-arab-spring-28575/>
- Huffpost, (2011, March 4), Arab Revolutions: From Tunisia To Egypt, Is This The Beginning Of A Trend? retrieved on May, 10, 2011 from http://www.huffingtonpost.com/2011/02/01/egypt-tunisia-arab-revolution_n_816695.html
- Lendman, S. (2011, May 22), Killings, Detentions and Torture in Egypt, *Inteldaily*, retrieved on May, 30, 2011 from <http://inteldaily.com/2011/05/killings-detentions-and-torture-in-egypt/>
- Martin, P. (2011, May 30), Mass protests demand "second revolution" in Egypt, *The Global Realm*, retrieved on May, 30, 2011 from <http://theglobalrealm.com/2011/05/30/mass-protests-demand-%E2%80%9Csecond-revolution%E2%80%9D-in-egypt/>
- MWC News, (2011, April 16) Syria's Emergency Law to be Lifted, retrieved on May, 12, 2011 from <http://mwcnews.net/news/middle-east/10045-syrias-emergency-law-to-be-lifted.html>
- NYTimes, (2011, June 8) Tunisia, retrieved on June, 10, 2011 from <http://topics.nytimes.com/top/news/international/countriesandterritories/tunisia/index.html?scp=1&sq=jasmine%20revolution&st=cse>
- Spiegel Online International, (2011) The Arab Revolution, retrieved on May, 15, 2011 from http://www.spiegel.de/international/topic/the_arab_revolution/
- Stratfor Global Intelligence, (2011) <http://www.stratfor.com/>
- The Economist, (Feb., 10, 2011) Where is the Next Upheaval? retrieved on April, 15, 2011 from <http://www.economist.com/node/18114401>
- The Week, (June, 1, 2011), Egypt's Revolting, Forced Virginity Tests, retrieved on June, 4, 2011 from <http://theweek.com/article/index/215815/egypts-revolting-forced-virginity-tests>
- Rezonansi, (2011, February 21), Georgia without Revolution? [sak'art'velo revoluc'iis gareše?]. Retrieved on April, 15, 2011 from http://www.resonance-daily.com/index.php?opt=post&id_post=50